

**DAQ**

# **SCMP and Carrier System User Manual**

*Modular Signal Conditioning*

February 1997 Edition  
Part Number 321453A-01



### **Internet Support**

support@natinst.com

E-mail: info@natinst.com

FTP Site: ftp.natinst.com

Web Address: <http://www.natinst.com>



### **Bulletin Board Support**

BBS United States: (512) 794-5422

BBS United Kingdom: 01635 551422

BBS France: 01 48 65 15 59



### **Fax-on-Demand Support**

(512) 418-1111

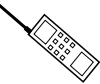

### **Telephone Support (U.S.)**

Tel: (512) 795-8248

Fax: (512) 794-5678

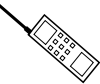

### **International Offices**

Australia 03 9879 5166, Austria 0662 45 79 90 0, Belgium 02 757 00 20,  
Canada (Ontario) 905 785 0085, Canada (Québec) 514 694 8521, Denmark 45 76 26 00,  
Finland 09 527 2321, France 01 48 14 24 24, Germany 089 741 31 30, Hong Kong 2645 3186,  
Israel 03 5734815, Italy 02 413091, Japan 03 5472 2970, Korea 02 596 7456,  
Mexico 5 520 2635, Netherlands 0348 433466, Norway 32 84 84 00, Singapore 2265886,  
Spain 91 640 0085, Sweden 08 730 49 70, Switzerland 056 200 51 51, Taiwan 02 377 1200,  
U.K. 01635 523545

### **National Instruments Corporate Headquarters**

6504 Bridge Point Parkway Austin, TX 78730-5039 Tel: (512) 794-0100

# Important Information

---

## Warranty

The VXI-SC-1150 and SCMPs are warranted against defects in materials and workmanship for a period of one year from the date of shipment, as evidenced by receipts or other documentation. National Instruments will, at its option, repair or replace equipment that proves to be defective during the warranty period. This warranty includes parts and labor.

The media on which you receive National Instruments software are warranted not to fail to execute programming instructions, due to defects in materials and workmanship, for a period of 90 days from date of shipment, as evidenced by receipts or other documentation. National Instruments will, at its option, repair or replace software media that do not execute programming instructions if National Instruments receives notice of such defects during the warranty period. National Instruments does not warrant that the operation of the software shall be uninterrupted or error free.

A Return Material Authorization (RMA) number must be obtained from the factory and clearly marked on the outside of the package before any equipment will be accepted for warranty work. National Instruments will pay the shipping costs of returning to the owner parts which are covered by warranty.

National Instruments believes that the information in this manual is accurate. The document has been carefully reviewed for technical accuracy. In the event that technical or typographical errors exist, National Instruments reserves the right to make changes to subsequent editions of this document without prior notice to holders of this edition. The reader should consult National Instruments if errors are suspected. In no event shall National Instruments be liable for any damages arising out of or related to this document or the information contained in it.

EXCEPT AS SPECIFIED HEREIN, NATIONAL INSTRUMENTS MAKES NO WARRANTIES, EXPRESS OR IMPLIED, AND SPECIFICALLY DISCLAIMS ANY WARRANTY OF MERCHANTABILITY OR FITNESS FOR A PARTICULAR PURPOSE. CUSTOMER'S RIGHT TO RECOVER DAMAGES CAUSED BY FAULT OR NEGLIGENCE ON THE PART OF NATIONAL INSTRUMENTS SHALL BE LIMITED TO THE AMOUNT THEREFORE PAID BY THE CUSTOMER. NATIONAL INSTRUMENTS WILL NOT BE LIABLE FOR DAMAGES RESULTING FROM LOSS OF DATA, PROFITS, USE OF PRODUCTS, OR INCIDENTAL OR CONSEQUENTIAL DAMAGES, EVEN IF ADVISED OF THE POSSIBILITY THEREOF. This limitation of the liability of National Instruments will apply regardless of the form of action, whether in contract or tort, including negligence. Any action against National Instruments must be brought within one year after the cause of action accrues. National Instruments shall not be liable for any delay in performance due to causes beyond its reasonable control. The warranty provided herein does not cover damages, defects, malfunctions, or service failures caused by owner's failure to follow the National Instruments installation, operation, or maintenance instructions; owner's modification of the product; owner's abuse, misuse, or negligent acts; and power failure or surges, fire, flood, accident, actions of third parties, or other events outside reasonable control.

## Copyright

Under the copyright laws, this publication may not be reproduced or transmitted in any form, electronic or mechanical, including photocopying, recording, storing in an information retrieval system, or translating, in whole or in part, without the prior written consent of National Instruments Corporation.

## Trademarks

LabVIEW®, NI-DAQ®, ComponentWorks™, CVI™, NI-VISA™, NI-VXI™, SCXI™, and VirtualBench™ are trademarks of National Instruments Corporation. Product and company names listed are trademarks or trade names of their respective companies.

## WARNING REGARDING MEDICAL AND CLINICAL USE OF NATIONAL INSTRUMENTS PRODUCTS

National Instruments products are not designed with components and testing intended to ensure a level of reliability suitable for use in treatment and diagnosis of humans. Applications of National Instruments products involving medical or clinical treatment can create a potential for accidental injury caused by product failure, or by errors on the part of the user or application designer. Any use or application of National Instruments products for or involving medical or clinical treatment must be performed by properly trained and qualified medical personnel, and all traditional medical safeguards, equipment, and procedures that are appropriate in the particular situation to prevent serious injury or death should always continue to be used when National Instruments products are being used. National Instruments products are NOT intended to be a substitute for any form of established process, procedure, or equipment used to monitor or safeguard human health and safety in medical or clinical treatment.



*Table  
of  
Contents*

---

## About This Manual

|  |      |
|--|------|
| Organization of This Manual .....        | vii  |
| Conventions Used in This Manual .....    | viii |
| National Instruments Documentation ..... | viii |
| Related Documentation.....               | ix   |
| Customer Communication .....             | ix   |

## Chapter 1

### Introduction

|  |     |
|--|-----|
| About the VXI-SC-1150 Signal Conditioning System ..... | 1-1 |
| What You Need to Get Started .....                     | 1-3 |
| Software Programming Choices .....                     | 1-3 |
| National Instruments Application Software .....        | 1-4 |
| NI-DAQ Driver Software .....                           | 1-4 |
| VXI <i>plug&amp;play</i> Instrument Driver .....       | 1-5 |
| Optional Equipment.....                                | 1-6 |
| Unpacking .....  | 1-6 |

## Chapter 2

### Installation

|  |     |
|--|-----|
| Installing the SCMPs into the SCMP Sockets ..... | 2-1 |
|--|-----|

## Chapter 3

### Hardware Overview

|  |     |
|--|-----|
| SCMP .....                             | 3-1 |
| Current Excitation .....               | 3-1 |
| Power Sharing .....                    | 3-2 |
| Transducer Connection and Wiring ..... | 3-2 |
| Voltage Excitation .....               | 3-4 |
| Power Sharing .....                    | 3-6 |
| Transducer Connection and Wiring ..... | 3-8 |

## Chapter 4 Signal Connections

|   |     |
|---|-----|
| Current Excitation SCMP Pin Assignments ..... | 4-1 |
| Voltage Excitation SCMP Pin Assignments ..... | 4-3 |

## Appendix A Specifications

## Appendix B Customer Communication

## Glossary

## Index

## Figures

|  |     |
|--|-----|
| Figure 1-1. Components of a VXI Signal Conditioning System .....   | 1-2 |
| Figure 1-2. The Relationship between the Programming Environment,<br>Your Instrument Driver, and Your VXI-DAQ Hardware ..... | 1-5 |
| Figure 2-1. Installing an SCMP .....   | 2-2 |
| Figure 3-1. Four-Wire, Three-Wire, Two-Wire, or Full-Bridge Configurations .....   | 3-3 |
| Figure 3-2. Quarter-Bridge Completion Resistors .....  | 3-5 |
| Figure 3-3. Full-Bridge, Half-Bridge, and Quarter-Bridge Configuration .....   | 3-9 |
| Figure 4-1. Current Excitation SCMP Pin Assignments for SCMP Socket 0 .....  | 4-1 |
| Figure 4-2. Current Excitation SCMP Pin Assignments for SCMP Socket 1 .....  | 4-2 |
| Figure 4-3. Current Excitation SCMP Pin Assignments for SCMP Socket 2 .....  | 4-2 |
| Figure 4-4. Current Excitation SCMP Pin Assignments for SCMP Socket 3 .....  | 4-2 |
| Figure 4-5. Voltage Excitation SCMP Pin Assignments for SCMP Socket 0 .....  | 4-3 |
| Figure 4-6. Voltage Excitation SCMP Pin Assignments for SCMP Socket 1 .....  | 4-4 |
| Figure 4-7. Voltage Excitation SCMP Pin Assignments for SCMP Socket 2 .....  | 4-4 |
| Figure 4-8. Voltage Excitation SCMP Pin Assignments for SCMP Socket 3 .....  | 4-4 |

## Tables

|   |     |
|---|-----|
| Table 3-1. SCMP Current Excitation Products .....                               | 3-1 |
| Table 3-2. SCMP Voltage Excitation Products .....                               | 3-4 |
| Table 3-3. Quarter-Bridge Completion Resistors and Corresponding Channels ..... | 3-5 |



*About  
This  
Manual*

---

The *SCMP and Carrier System User Manual* describes the features, functions, and operation of the signal conditioning minipods (SCMPs) and the VXI-SC-1150 carrier system.

## Organization of This Manual

---

The *SCMP and Carrier System User Manual* is organized as follows:

- Chapter 1, *Introduction*, describes the VXI-SC-1150 submodule and signal conditioning minipods (SCMPs), lists what you need to get started, optional equipment, and software programming choices, and explains how to unpack your submodule and SCMPs.
- Chapter 2, *Installation*, describes how to install your SCMPs.
- Chapter 3, *Hardware Overview*, explains the operation of each functional unit of the SCMPs.
- Chapter 4, *Signal Connections*, describes how to make signal connections to your SCMP sockets via the *VXI-SC-1150* front connector.
- Appendix A, *Specifications*, lists the specifications of the VXI-SC-1150 and the SCMPs.
- Appendix B, *Customer Communication*, contains forms you can use to request help from National Instruments or to comment on our products and manuals.
- The *Glossary* contains an alphabetical list and description of terms used in this manual, including abbreviations, acronyms, definitions, metric prefixes, mnemonics, and symbols.
- The *Index* contains an alphabetical list of key terms and topics in this manual, including the page where you can find each one.

## Conventions Used in This Manual

---

|                           |   |
|---------------------------|---|
|                           | The following conventions are used in this manual:  |
| <b><i>bold italic</i></b> | Bold italic text denotes a note, caution, or warning.   |
| carrier system            | Refers to the VXI-SC-1150 and one or more SCMPs.  |
| <i>italic</i>             | Italic text denotes emphasis, a cross reference, or an introduction to a key concept.   |
| monospace                 | Text in this font denotes text or characters that are to be literally input from the keyboard, sections of code, programming examples, and syntax examples. This font is also used for the proper names of disk drives, paths, directories, programs, subprograms, subroutines, device names, functions, variables, filenames, and extensions, and for statements and comments taken from program code. |
| <>                        | Angle brackets containing numbers separated by an ellipsis represent a range of values associated with a bit, signal, or port (for example, ACH<0..7> stands for ACH0 through ACH7).  |
| module                    | Refers to the VXI-SC-1000 carrier module, unless otherwise noted.   |
| NI-DAQ                    | NI-DAQ refers to NI-DAQ software for PC compatibles, unless otherwise noted.  |
| SCXI                      | SCXI stands for Signal Conditioning eXtensions for Instrumentation and is a National Instruments product line designed to perform front-end signal conditioning for National Instruments plug-in DAQ boards.  |
| submodule                 | Refers to the VXI-SC-1150, unless otherwise noted.  |
|                           | Abbreviations, acronyms, metric prefixes, mnemonics, symbols, and terms are listed in the <i>Glossary</i> .   |

## National Instruments Documentation

---

The *SCMP and Carrier System User Manual* is one piece of the documentation set for your VXI-data acquisition (VXI-DAQ) system. You could have any of several types of manuals, depending on the hardware and software in your system. Use the different types of manuals you have as follows:

- Your VXI-DAQ hardware user manuals—These manuals have detailed information about the VXI-DAQ hardware that plugs into or is connected to your computer. Use these manuals for hardware

installation and configuration instructions, specification information about your VXI-DAQ hardware, and application hints.

- Software documentation—You may have both application software and driver software documentation. National Instruments application software includes ComponentWorks, LabVIEW, LabWindows<sup>®</sup>/CVI, Measure, and VirtualBench. National Instruments driver software includes NI-DAQ and VXI*plug&play* instrument drivers. After you set up your hardware system, use either your application or driver software documentation to help you write your application. If you have a large, complicated system, it is worthwhile to look through the software documentation before you configure your hardware.
- Accessory installation guides or manuals—If you are using accessory products, read the terminal block and cable assembly installation guides or accessory board user manuals. They explain how to physically connect the relevant pieces of the system. Consult these guides when you are making your connections.

## Related Documentation

---

The following documents contain information that you may find helpful as you read this manual:

- *VXI-SC-1000 Carrier Module Installation Guide*
- *VXI-MIO Series User Manual*
- *VXI-TB-196/296 Terminal Block Installation Guide* or *TBX-96 Terminal Block Installation Guide*

## Customer Communication

---

National Instruments wants to receive your comments on our products and manuals. We are interested in the applications you develop with our products, and we want to help if you have problems with them. To make it easy for you to contact us, this manual contains comment and configuration forms for you to complete. These forms are in Appendix B, *Customer Communication*, at the end of this manual.



# Introduction

---

*Chapter*

**1**

This chapter describes the VXI-SC-1150 submodule and signal conditioning minipods (SCMPs), lists what you need to get started, optional equipment, and software programming choices, and explains how to unpack your submodule and SCMPs.

## About the VXI-SC-1150 Signal Conditioning System

---

The VXI-SC-1150 is a submodule that connects to a VXIbus chassis via the VXI-SC-1000 carrier module. The SCMPs are modular boards that can plug on a VXI-SC-1150 submodule to provide various signal conditioning functions.

The VXI-SC-1150 and SCMPs are part of a VXI signal conditioning system, which consists of the components listed below and shown in Figure 1-1.

- The VXI-SC-1000 is a carrier module that installs into a VXI slot in a VXIbus chassis. The VXI-SC-1000 is populated with one or two submodules.
- The VXI-SC-1150 and VXI-SC-1102 are submodules that install into VXI-SC subslots on a VXI-SC-1000 carrier module.
- SCMPs are small modular boards that install into SCMP sockets on a VXI-SC-1150 submodule.

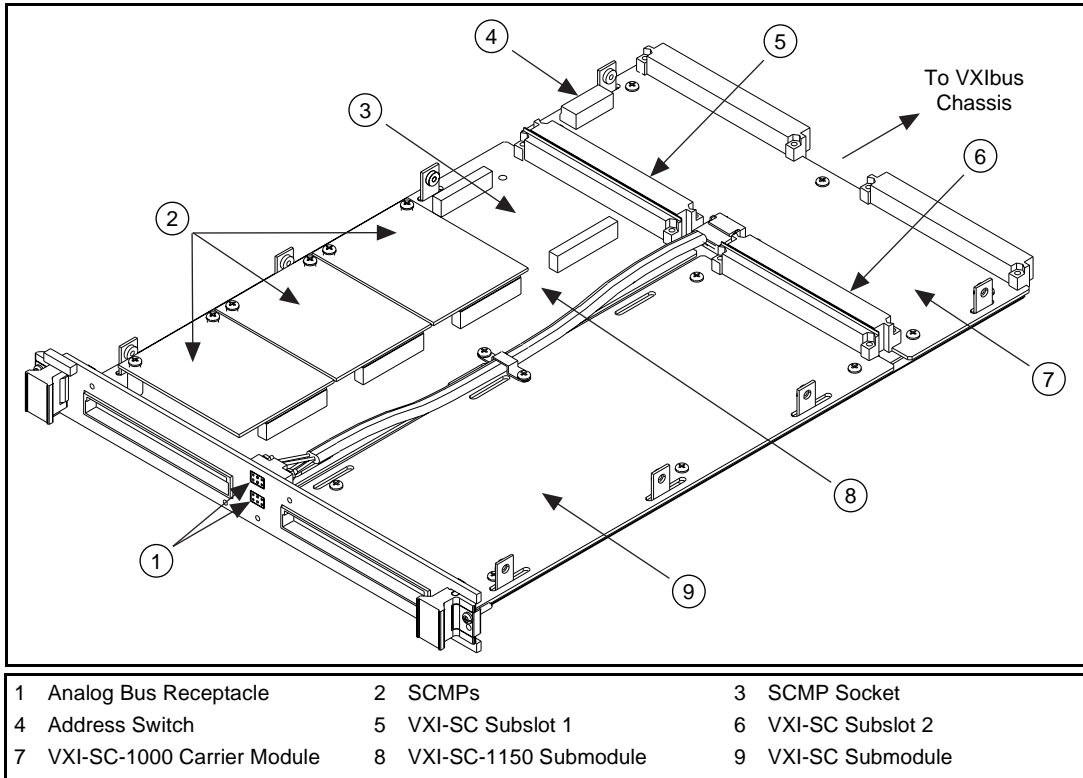

**Figure 1-1.** Components of a VXI Signal Conditioning System

The VXI-SC-1150 is designed to work in conjunction with other VXI-SC submodules, such as the VXI-SC-1102, to provide a total solution for transducer conditioning. When the VXI-SC-1150 is populated with the current excitation SCMPs and voltage excitation SCMPs, you can use these as excitation sources to excite transducers such as RTDs, strain gauges, thermistors, and resistors.

The VXI-SC-1150 is divided into four SCMP sockets, each with two connectors. The 24-pin connector provides connection between the front 96-pin DIN connector and the SCMPs. The 28-pin connector provides power and a communication channel to the SCMP from the VXI-SC-1000 carrier module.

Each SCMP has an individual ID and can be recognized by the VXI-SC-1150 and passed along to the NI-DAQ Configuration Utility,

which reports it to you. Hence, this permits auto-configuration and provides you with a means of controlling and recognizing your setup.

## What You Need to Get Started

---

- VXI-SC-1000 carrier module and installation guide
- VXI-SC-1150 and one or more SCMPs
- SCMP and Carrier System User Manual*
- VXIbus chassis and documentation
- VXI-MIO module and documentation
- SCXI chassis and documentation (optional)
- VXI-TB-196/296 terminal block (optional)
- TBX terminal block (optional)
- one of the following packages and documentation:
  - LabVIEW for Windows
  - LabWindows/CVI for Windows
  - NI-DAQ for PC compatibles
  - ComponentWorks
  - VirtualBench
  - VXI*plug&play* instrument driver

## Software Programming Choices

---

There are several options to choose from when programming your National Instruments VXI-DAQ hardware. You can use LabVIEW, LabWindows/CVI, ComponentWorks, VirtualBench, or other application development environments with either NI-DAQ or the VXI*plug&play* instrument driver. Both NI-DAQ and the VXI*plug&play* instrument driver access the VXI-DAQ hardware through the VISA driver software.

## National Instruments Application Software

LabVIEW features interactive graphics, a state-of-the-art user interface, and a powerful graphical programming language. The LabVIEW Data Acquisition VI Library, a series of VIs for using LabVIEW with National Instruments DAQ hardware, is included with LabVIEW. The LabVIEW Data Acquisition VI Library is functionally equivalent to the NI-DAQ software.

LabWindows/CVI features interactive graphics, a state-of-the-art user interface, and uses the ANSI standard C programming language. The LabWindows/CVI Data Acquisition Library, a series of functions for using LabWindows/CVI with National Instruments DAQ hardware, is included with the NI-DAQ software kit. The LabWindows/CVI Data Acquisition Library is functionally equivalent to the NI-DAQ software.

ComponentWorks contains tools for data acquisition and instrument control built on NI-DAQ driver software. ComponentWorks provides a higher-level programming interface for building virtual instruments through standard OLE controls and DLLs. With ComponentWorks, you can use all of the configuration tools, resource management utilities, and interactive control utilities included with NI-DAQ.

VirtualBench features VIs that combine DAQ products, software, and your computer to create a standalone instrument with the added benefit of the processing, display, and storage capabilities of your computer. VirtualBench instruments load and save waveform data to disk in the same forms that can be used in popular spreadsheet programs and word processors.

Using ComponentWorks, LabVIEW, LabWindows/CVI, or VirtualBench software will greatly reduce the development time for your data acquisition and control application.

## NI-DAQ Driver Software

The NI-DAQ driver software is included at no charge with all National Instruments DAQ hardware. NI-DAQ is not packaged with accessory products. NI-DAQ has an extensive library of functions that you can call from your application programming environment. These functions include routines for analog input (A/D conversion), buffered data acquisition (high-speed A/D conversion), analog output (D/A conversion), waveform generation, digital I/O, counter/timer operations, SCXI, RTSI, self-calibration, messaging, and acquiring data to extended memory.

NI-DAQ has both high-level DAQ I/O functions for maximum ease of use and low-level DAQ I/O functions for maximum flexibility and performance. Examples of high-level functions are streaming data to disk or acquiring a certain number of data points. An example of a low-level function is writing directly to registers on the DAQ device. NI-DAQ does not sacrifice the performance of National Instruments DAQ devices because it lets multiple devices operate at their peak performance.

NI-DAQ maintains a consistent software interface among its different versions so that you can change platforms with minimal modifications to your code.

## VXIplug&play Instrument Driver

National Instruments distributes *VXIplug&play* instrument drivers free of charge. *VXIplug&play* instrument drivers are one level above the NI-DAQ device driver and contain high-level software functions whose architecture is specified by the *VXIplug&play* Systems Alliance. The *VXIplug&play* standards increase interoperability with other vendors, and ensure that drivers are designed and presented in a consistent fashion that facilitates ease of use. Refer to Figure 1-2 to see the relationship between your software components.

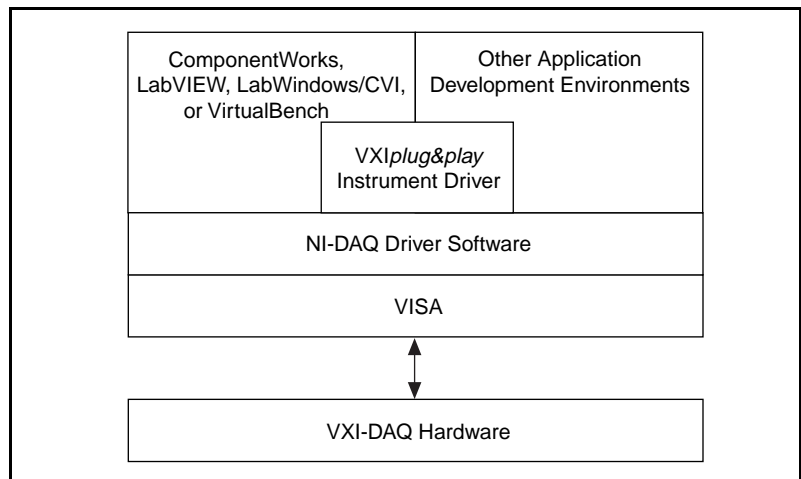

**Figure 1-2.** The Relationship between the Programming Environment, Your Instrument Driver, and Your VXI-DAQ Hardware

## Optional Equipment

---

National Instruments offers a variety of products to use with your VXI-SC-1150 and SCMPs, as follows:

- Terminal blocks to attach signals to your submodule
- Quarter-bridge completion resistors

For more specific information about these products, refer to your National Instruments catalogue or call the office nearest you.

## Unpacking

---

Your VXI-SC-1150 and SCMPs are shipped in an antistatic package to prevent electrostatic damage to the submodule and SCMP. Electrostatic discharge can damage several components on the submodule and SCMP. To avoid such damage in handling, take the following precautions.

- Ground yourself via a grounding strap or by holding a grounded object.
- Touch the antistatic package to a metal part of your VXIbus chassis before removing the submodule or SCMP from the package.
- Remove the submodule or SCMP from the package and inspect it for loose components or any other sign of damage. Notify National Instruments if the submodule or SCMP appears damaged in any way. *Do not* install a damaged submodule into your VXIbus chassis or a damaged SCMP onto your submodule.
- *Never* touch the exposed pins of connectors.

# Installation

---

Chapter

2

This chapter describes how to install your SCMPs. See your *VXI-SC-1000 Carrier Module Installation Guide* for instructions on how to install your VXI-SC-1150 submodule into the VXI-SC-1000 carrier module.

## Installing the SCMPs into the SCMP Sockets

---

The VXI-SC-1150 SCMP sockets are labeled 0 through 3. An SCMP plugged into a socket is referred to as SCMP  $n$  where  $n$  is the socket number. For example, an SCMP in *socket 3* will be referred to as *SCMP 3*. Please refer to Figure 2-1 for the location of these SCMP sockets.

If this is a first-time installation, you can assemble your SCMPs directly onto your VXI-SC-1150 submodule before installing the submodule into the VXI-SC-1000 carrier module. If your VXI-SC-1150 is already installed in a VXI-SC-1000 carrier module (i.e., if you are adding or replacing an SCMP), you do not need to remove the VXI-SC-1150. Simply remove the top cover of the VXI-SC-1000 carrier module by removing the eight flathead screws. You can then gain access to the VXI-SC-1150 to install SCMPs.

1. Plug the SCMP into the desired socket (the sockets are keyed so that you cannot place the SCMP backwards).
2. Use the screws that were provided with your SCMP to secure it. Do not overtighten the screws.
3. When you have installed all SCMPs, install your VXI-SC-1150 into the VXI-SC-1000 carrier module.

If your VXI-SC-1150 was already installed in a VXI-SC-1000 carrier module, simply re-install the top cover using the eight flathead screws.

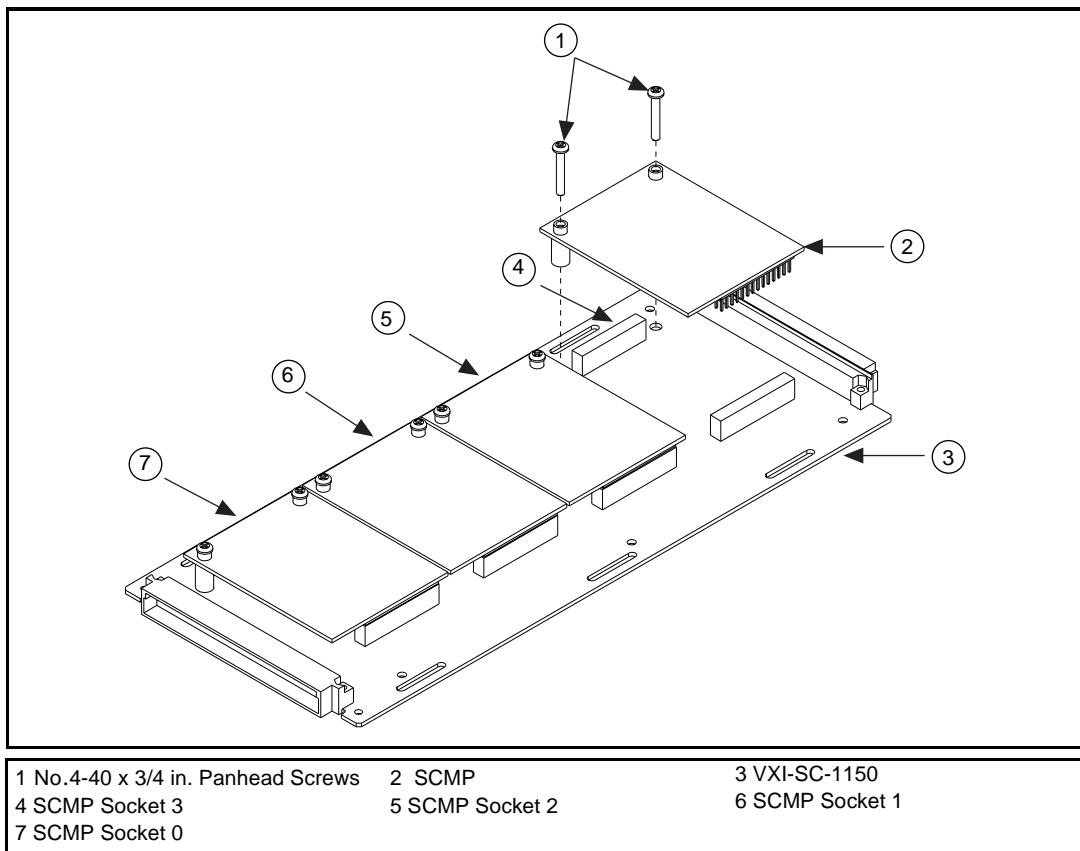

**Figure 2-1.** Installing an SCMP



# Hardware Overview

Chapter

3

This chapter explains the operation of each functional unit of the SCMPs.

## SCMP

### Current Excitation

The current excitation SCMPs are designed to provide current excitation to a variety of resistive sensors, including RTDs, thermistors, strain gauges, and resistances. Each SCMP has a unique SCMP ID that allows for automatic recognition and configuration upon installation. The current excitation SCMP products are listed in Table 3-1.

**Table 3-1.** SCMP Current Excitation Products

| Product          | Excitation  | Functionality | SCMP ID (Decimal) |
|------------------|-------------|---------------|-------------------|
| SCMP-10 $\mu$ A  | 10 $\mu$ A  | DC, Fixed     | 1                 |
| SCMP-100 $\mu$ A | 100 $\mu$ A | DC, Fixed     | 2                 |
| SCMP-1mA         | 1 mA        | DC, Fixed     | 3                 |
| SCMP-13mA        | 13.333 mA   | DC, Fixed     | 4                 |

Each current excitation SCMP has eight channels, each comprising a ground referenced current excitation source. All channels have the same fixed excitation value.

You do not need to configure, adjust, or calibrate the SCMP current excitation products. Simply install the SCMP as shown in Chapter 2, *Installation*, and your current excitation SCMP is ready for use.

## Power Sharing

The power supply rails on the VXI-SC-1150 submodule are common to all sockets. This means that power used by an SCMP in one socket subtracts from the power available to SCMPs in other sockets. The available power per socket given in the VXI-SC-1150 submodule specifications is the total power available divided by four sockets, assuming equal power sharing among sockets. However, you are allowed to use SCMPs that consume more than their allotted share (up to the total power available to both subslots on the VXI-SC-1000 carrier module) as long as your overall configuration of SCMPs does not exceed the total power available on any of the power supply rails. When using SCMPs with loads that cause their power consumption to exceed the socket specifications, you should do a careful power budget for your desired configuration of SCMPs to ensure that the carrier module power supplies are never overloaded.

The SCMP-13mA is the only current excitation SCMP that uses more power (from the +12 V line) than the socket allotment when all eight channels are used. This SCMP uses 120 mA from the +12 V power rail when all eight channels are loaded. The maximum current available on the +12 V supply of the VXI-SC-1150 submodule is 62 mA per socket. A fully loaded SCMP-13mA uses almost twice the +12 V current allotted to its socket.

## Transducer Connection and Wiring

You can connect transducers to your current excitation SCMPs in four-wire, three-wire, two-wire, or full-bridge configurations via your terminal block. The output signals can be routed either to a signal conditioner such as the VXI-SC-1102 before digitizing or directly to a digitizer such as a VXI-MIO E Series module. Figure 3-1 illustrates examples of the transducer configurations and connections.

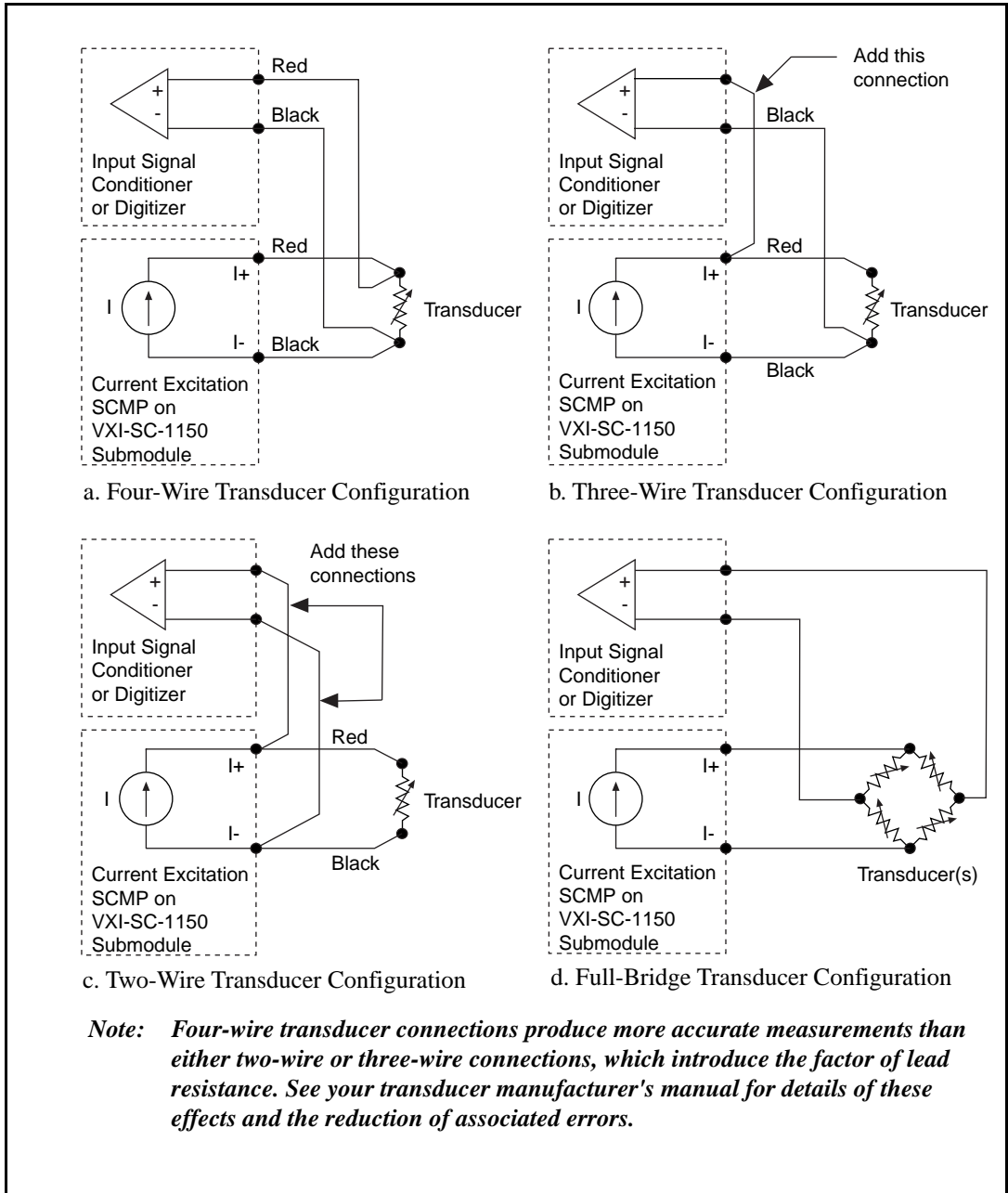

**Figure 3-1.** Four-Wire, Three-Wire, Two-Wire, or Full-Bridge Configurations

## Voltage Excitation

The voltage excitation SCMPs are designed to provide voltage excitation to a variety of resistive sensors in Wheatstone bridge configurations, including RTDs, thermistors, strain gauges, and resistances. These SCMPs also include half-bridge completion and provision for quarter-bridge completion. Each SCMP has a unique SCMP ID that allows for automatic recognition and configuration upon installation. The voltage excitation SCMP products are listed in Table 3-2.

**Table 3-2.** SCMP Voltage Excitation Products

| Product  | Excitation | Functionality | SCMP ID (Decimal) |
|----------|------------|---------------|-------------------|
| SCMP-1V  | 1 V        | DC, Fixed     | 5                 |
| SCMP-2V  | 2 V        | DC, Fixed     | 6                 |
| SCMP-5V  | 5 V        | DC, Fixed     | 7                 |
| SCMP-10V | 10 V       | DC, Fixed     | 8                 |

Each voltage excitation SCMP consists of one fixed, ground referenced voltage excitation source and one half-bridge reference routed to eight channels. These voltage excitation sources do not provide remote sensing. Therefore, the accuracy of the excitation outputs will be reduced due to an error equal to the lead wire resistance multiplied by the bridge current. Each channel also features sockets for its own quarter-bridge completion resistor. Voltage excitation SCMPs are shipped from the factory with all channels configured for full-bridge or half-bridge completion. To configure a channel for quarter-bridge completion, remove the factory-installed 0  $\Omega$  resistor from the corresponding channel and insert your quarter-bridge completion resistor. Figure 3-2 shows where these quarter-bridge completion resistors are located. Table 3-3 lists the quarter-bridge completion resistors and corresponding channels.

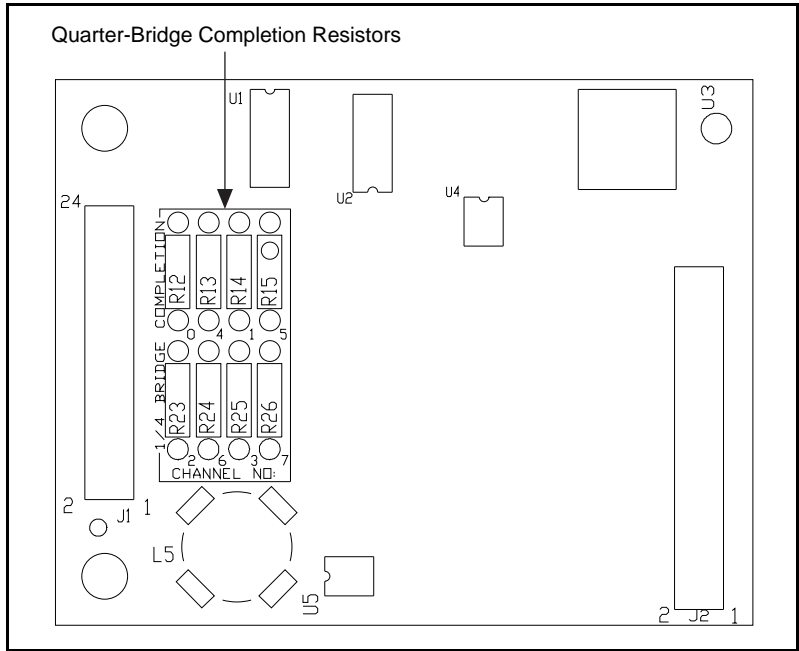

**Figure 3-2.** Quarter-Bridge Completion Resistors

**Table 3-3.** Quarter-Bridge Completion Resistors and Corresponding Channels

| Channel | Resistor |
|---------|----------|
| 0       | R12      |
| 1       | R14      |
| 2       | R23      |
| 3       | R25      |
| 4       | R13      |
| 5       | R15      |
| 6       | R24      |
| 7       | R26      |

You do not need to adjust or calibrate the voltage excitation SCMP products. After configuring your SCMP channels for bridge completion, install it onto the VXI-SC-1150 submodule as shown in Chapter 2, *Installation*; your voltage excitation SCMP is ready to use.

## Power Sharing

The power supply rails on the VXI-SC-1150 submodule are common to all sockets. This means that power used by an SCMP in one socket subtracts from the power available to SCMPs in other sockets. The available power per socket given in the VXI-SC-1150 submodule specifications is the total power available divided by four sockets, assuming equal power sharing among sockets. However, you are allowed to use SCMP that consume more than their allotted share (up to the total power available to both subslots on the VXI-SC-1000 carrier module) as long as your overall configuration of SCMPs does not exceed the total power available on any of the power supply rails. When using SCMPs with loads that cause their power consumption to exceed the socket specifications, you should do a careful power budget for your desired configuration of SCMPs to ensure that the carrier module power supplies are never overloaded.

With the exception of the SCMP-1V, you can use all voltage excitation SCMPs with loads that cause them to draw more power than the socket specification from the power supply rails that supply their current drives.

The current drives of the SCMP-1V and SCMP-2V are supplied from the +5 V rail, and they draw 5 mA or less from this supply when unloaded. To determine the +5 V current required for these SCMPs to power your loads, calculate the current drive needed to excite the loads on the channels in use and add 5 mA. For example, you can use an SCMP-2V to excite eight 120  $\Omega$  full bridges. This combination of bridges represents a total load of 15  $\Omega$ . You can calculate the current required, as follows:

$$\begin{aligned}
 \text{current drive (total)} &= \text{output voltage/total load} \\
 &= 2 \text{ V}/15 \Omega \\
 &= 133.3 \text{ mA} \\
 +5 \text{ V current required} &= 5 \text{ mA} + \text{current drive (total)} \\
 &= 5 \text{ mA} + 133.3 \text{ mA} \\
 &= 138.3 \text{ mA}
 \end{aligned}$$

The current drive of the SCMP-5V is supplied from the +5 V rail and draws 10 mA or less from this supply when unloaded. To determine the +5 V current required for the SCMP-5V to power your loads, use the following approximation:

$$\begin{aligned} \text{+5 V current required} \\ \approx 10 \text{ mA} + [\text{current drive (total)} \times 1.72] \text{ mA.} \end{aligned}$$

For example, you can use the SCMP-5V to excite four 120  $\Omega$  full bridges and four 350  $\Omega$  full bridges. This combination of bridges represents a total load of 22.34  $\Omega$ . You can calculate the current required, as follows:

$$\begin{aligned} \text{current drive (total)} &= \text{output voltage/total load} \\ &= 5 \text{ V}/22.34 \text{ } \Omega \\ &= 223.8 \text{ mA} \\ \text{+5 V current required} &\approx 5 \text{ mA} + [223.8 \times 1.72] \text{ mA} \\ &\approx 5 \text{ mA} + 385 \text{ mA} \\ &\approx 390 \text{ mA} \end{aligned}$$

The current drive of the SCMP-10V is supplied from the +12 V rail and draws 1 mA or less from this supply when unloaded. To determine the +12 V current required for the SCMP-10V to power your loads, calculate the current drive needed to excite the loads on the channels in use and add 1 mA. For example, you can use the SCMP-10V to excite eight 750  $\Omega$  full bridges. This combination of bridges represents a total load of 93.75  $\Omega$ . You can calculate the current required, as follows:

$$\begin{aligned} \text{current drive (total)} &= \text{output voltage/total load} \\ &= 10 \text{ V}/93.75 \text{ } \Omega \\ &= 106.7 \text{ mA} \\ \text{+12 V current required} &= 1 \text{ mA} + \text{current drive (total)} \\ &= 1 \text{ mA} + 106.7 \text{ mA} \\ &= 107.7 \text{ mA} \end{aligned}$$

Refer to the voltage excitation SCMP specifications for additional information on the power consumption of each SCMP.

## Transducer Connection and Wiring

You can connect transducers to your voltage excitation SCMPs in full-bridge, half-bridge, and quarter-bridge configurations via your terminal block. Route the output signals either to a signal conditioner such as the VXI-SC-1102 located in the adjacent subslot before digitizing or directly to a digitizer such as a VXI-MIO E Series module. Figure 3-3 illustrates examples of the transducer configurations and connections.



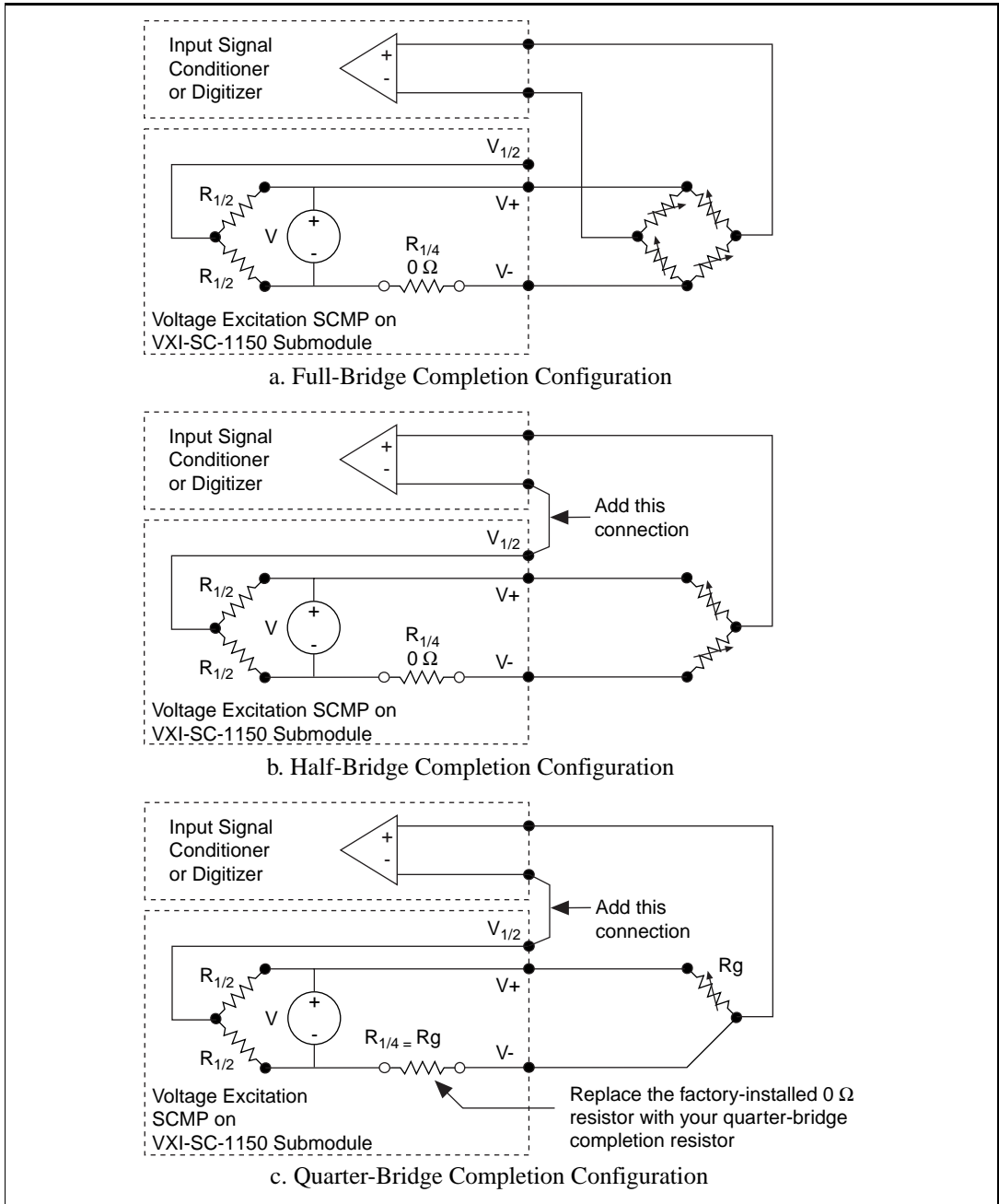

**Figure 3-3.** Full-Bridge, Half-Bridge, and Quarter-Bridge Configuration

# Signal Connections

Chapter

4

This chapter describes how to make signal connections to your SCMP sockets via the VXI-SC-1150 front connector.

## Current Excitation SCMP Pin Assignments

Each of the eight channels on a current excitation SCMP is routed to a pair of pins on the SCMP signal connector. This signal connector is mapped to a set of pins on the VXI-SC-1150 front connector via the socket on which the SCMP is mounted. Figures 4-1 through 4-4 show the SCMP signal connector pin mapping to the VXI-SC-1150 front connector pins for each SCMP socket. Front connector pins map one-to-one to the 96-pin screw terminals on your terminal block.

| A   |    | B   |    | C  |    |
|-----|----|-----|----|----|----|
| 13- | 25 | 17- | 25 | NC | 25 |
| 13+ | 26 | 17+ | 26 | NC | 26 |
| 12- | 27 | 16- | 27 | NC | 27 |
| 12+ | 28 | 16+ | 28 | NC | 28 |
| 11- | 29 | 15- | 29 | NC | 29 |
| 11+ | 30 | 15+ | 30 | NC | 30 |
| 10- | 31 | 14- | 31 | NC | 31 |
| 10+ | 32 | 14+ | 32 | NC | 32 |

**Figure 4-1.** Current Excitation SCMP Pin Assignments for SCMP Socket 0

| A   |    | B   |    | C  |    |
|-----|----|-----|----|----|----|
| I3- | 17 | I7- | 17 | NC | 17 |
| I3+ | 18 | I7+ | 18 | NC | 18 |
| I2- | 19 | I6- | 19 | NC | 19 |
| I2+ | 20 | I6+ | 20 | NC | 20 |
| I1- | 21 | I5- | 21 | NC | 21 |
| I1+ | 22 | I5+ | 22 | NC | 22 |
| I0- | 23 | I4- | 23 | NC | 23 |
| I0+ | 24 | I4+ | 24 | NC | 24 |

**Figure 4-2.** Current Excitation SCMP Pin Assignments for SCMP Socket 1

| A   |    | B   |    | C  |    |
|-----|----|-----|----|----|----|
| I3- | 9  | I7- | 9  | NC | 9  |
| I3+ | 10 | I7+ | 10 | NC | 10 |
| I2- | 11 | I6- | 11 | NC | 11 |
| I2+ | 12 | I6+ | 12 | NC | 12 |
| I1- | 13 | I5- | 13 | NC | 13 |
| I1+ | 14 | I5+ | 14 | NC | 14 |
| I0- | 15 | I4- | 15 | NC | 15 |
| I0+ | 16 | I4+ | 16 | NC | 16 |

**Figure 4-3.** Current Excitation SCMP Pin Assignments for SCMP Socket 2

| A   |   | B   |   | C  |   |
|-----|---|-----|---|----|---|
| I3- | 1 | I7- | 1 | NC | 1 |
| I3+ | 2 | I7+ | 2 | NC | 2 |
| I2- | 3 | I6- | 3 | NC | 3 |
| I2+ | 4 | I6+ | 4 | NC | 4 |
| I1- | 5 | I5- | 5 | NC | 5 |
| I1+ | 6 | I5+ | 6 | NC | 6 |
| I0- | 7 | I4- | 7 | NC | 7 |
| I0+ | 8 | I4+ | 8 | NC | 8 |

**Figure 4-4.** Current Excitation SCMP Pin Assignments for SCMP Socket 3

I<0..7>± are the current excitation output channels.

Sticker labels printed with SCMP signal names are also provided for use with the terminal block.

1. Select the set of sticker labels that corresponds to the type of terminal block you are using.
2. Peel off the labels and apply them to the top of the screw terminals associated with the SCMP socket on which your SCMP is mounted.
3. If you are using a VXI-TB-196/296 terminal block, fill in the excitation value of your SCMP on the VXI-SC-1150 Help Card and install the Help Card in the appropriate section in the terminal block. Refer to the *VXI-TB-196/296 Terminal Block Installation Guide* for details.

## Voltage Excitation SCMP Pin Assignments

Each of the eight channels on a voltage excitation SCMP is routed to three pins on the SCMP signal connector. This signal connector is mapped to a set of pins on the VXI-SC-1150 submodule front connector via the socket on which the SCMP is mounted. Figures 4-5 through 4-8 show the SCMP signal connector pin mapping to the front connector pins for each of the four sockets on the VXI-SC-1150. Front connector pins map one-to-one to the 96-pin screw terminals on your terminal block.

|     | A  |     | B  |       | C  |
|-----|----|-----|----|-------|----|
| V3- | 25 | V7- | 25 | 1/2V7 | 25 |
| V3+ | 26 | V7+ | 26 | 1/2V6 | 26 |
| V2- | 27 | V6- | 27 | 1/2V5 | 27 |
| V2+ | 28 | V6+ | 28 | 1/2V4 | 28 |
| V1- | 29 | V5- | 29 | 1/2V3 | 29 |
| V1+ | 30 | V5+ | 30 | 1/2V2 | 30 |
| V0- | 31 | V4- | 31 | 1/2V1 | 31 |
| V0+ | 32 | V4+ | 32 | 1/2V0 | 32 |

**Figure 4-5.** Voltage Excitation SCMP Pin Assignments for SCMP Socket 0

| A   |    | B   |    | C     |    |
|-----|----|-----|----|-------|----|
| V3- | 17 | V7- | 17 | 1/2V7 | 17 |
| V3+ | 18 | V7+ | 18 | 1/2V6 | 18 |
| V2- | 19 | V6- | 19 | 1/2V5 | 19 |
| V2+ | 20 | V6+ | 20 | 1/2V4 | 20 |
| V1- | 21 | V5- | 21 | 1/2V3 | 21 |
| V1+ | 22 | V5+ | 22 | 1/2V2 | 22 |
| V0- | 23 | V4- | 23 | 1/2V1 | 23 |
| V0+ | 24 | V4+ | 24 | 1/2V0 | 24 |

**Figure 4-6.** Voltage Excitation SCMP Pin Assignments for SCMP Socket 1

| A   |    | B   |    | C     |    |
|-----|----|-----|----|-------|----|
| V3- | 9  | V7- | 9  | 1/2V7 | 9  |
| V3+ | 10 | V7+ | 10 | 1/2V6 | 10 |
| V2- | 11 | V6- | 11 | 1/2V5 | 11 |
| V2+ | 12 | V6+ | 12 | 1/2V4 | 12 |
| V1- | 13 | V5- | 13 | 1/2V3 | 13 |
| V1+ | 14 | V5+ | 14 | 1/2V2 | 14 |
| V0- | 15 | V4- | 15 | 1/2V1 | 15 |
| V0+ | 16 | V4+ | 16 | 1/2V0 | 16 |

**Figure 4-7.** Voltage Excitation SCMP Pin Assignments for SCMP Socket 2

| A   |   | B   |   | C     |   |
|-----|---|-----|---|-------|---|
| V3- | 1 | V7- | 1 | 1/2V7 | 1 |
| V3+ | 2 | V7+ | 2 | 1/2V6 | 2 |
| V2- | 3 | V6- | 3 | 1/2V5 | 3 |
| V2+ | 4 | V6+ | 4 | 1/2V4 | 4 |
| V1- | 5 | V5- | 5 | 1/2V3 | 5 |
| V1+ | 6 | V5+ | 6 | 1/2V2 | 6 |
| V0- | 7 | V4- | 7 | 1/2V1 | 7 |
| V0+ | 8 | V4+ | 8 | 1/2V0 | 8 |

**Figure 4-8.** Voltage Excitation SCMP Pin Assignments for SCMP Socket 3

$V_{<0..7>\pm}$  are the voltage excitation output channels.

$1/2V_{<0..7>}$  are the half-bridge completion output channels.

Sticker labels printed with SCMP signal names are also provided for use with the terminal block.

1. Select the set of sticker labels that corresponds to the type of terminal block you are using.
2. Peel off the labels and apply them to the top of the screw terminals associated with the SCMP socket on which your SCMP is mounted.
3. If you are using a VXI-TB-196 terminal block, fill in the excitation value of your SCMP on the VXI-SC-1150 Help Card and install the Help Card in the appropriate section in the terminal block. Refer to the *VXI-TB-196/296 Terminal Block Installation Guide* for details.

# Specifications

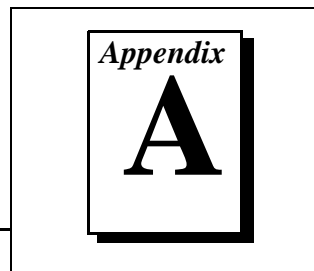

This section lists the specifications of the VXI-SC-1150 and the SCMPs. These specifications are typical at 25° C unless otherwise noted.

## VXI-SC-1150 Submodule

### Physical

Operating temperature .....0 to 50° C  
Relative Humidity .....5% to 90% noncondensing  
Dimensions .....115 by 273 mm  
4.54 by 10.75 in.

### Power

Power consumption .....2 mA at 5 V, 1 mA at -24 V and  
1 mA at +24 V

Available power per socket<sup>1</sup>

|  |        |        |        |        |        |       |        |
|--|--------|--------|--------|--------|--------|-------|--------|
| +12 V  | -12 V  | +15 V* | -15 V* | +5 V   | -5.2 V | +24 V | -24 V  |
| 62 mA  | -45 mA | 45 mA  | -45 mA | 156 mA | -62 mA | 45 mA | -45 mA |
| * Any power used from these supplies reduces respectively from the ±24 V available power |        |        |        |        |        |       |        |

1. You can use more power in a given SCMP socket, but this will result in less power available to the other sockets or subslots.

# SCMP

## Current Excitation

These specifications are for the 10  $\mu\text{A}$ , 100  $\mu\text{A}$ , 1 mA, and 13 mA SCMPs.

## Stability

Recommended warm-up time ..... 10 min.

## Excitation

|                           | SCMP-10 $\mu\text{A}$              | SCMP-100 $\mu\text{A}$             | SCMP-1mA                           | SCMP-13mA                          |
|---------------------------|------------------------------------|------------------------------------|------------------------------------|------------------------------------|
| Channels                  | 8                                  | 8                                  | 8                                  | 8                                  |
| Level                     | 10 $\mu\text{A}$                   | 100 $\mu\text{A}$                  | 1 mA                               | 13.333 mA                          |
| Accuracy                  | $\pm 0.05\%$                       | $\pm 0.05\%$                       | $\pm 0.05\%$                       | $\pm 0.09\%$                       |
| Drift                     | $\pm 5 \text{ ppm}/^\circ\text{C}$ | $\pm 5 \text{ ppm}/^\circ\text{C}$ | $\pm 5 \text{ ppm}/^\circ\text{C}$ | $\pm 6 \text{ ppm}/^\circ\text{C}$ |
| Output Voltage Compliance | 10 V                               | 10 V                               | 10 V                               | 10 V                               |
| Maximum Resistive Load    | 1 M $\Omega$                       | 100 k $\Omega$                     | 10 k $\Omega$                      | 750 $\Omega$                       |
| Over-voltage Protection   | $\pm 40 \text{ V}$                 | $\pm 40 \text{ V}$                 | $\pm 40 \text{ V}$                 | $\pm 40 \text{ V}$                 |



## Power Requirement

|  | SCMP-<br>10 $\mu$ A | SCMP-<br>100 $\mu$ A | SCMP<br>-1mA       | SCMP-<br>13mA         |
|--|---------------------|----------------------|--------------------|-----------------------|
| +5 VDC ( $\pm 5\%$ )   | 10 $\mu$ A          | 10 $\mu$ A           | 10 $\mu$ A         | 10 $\mu$ A            |
| +12 VDC ( $\pm 5\%$ )  | —                   | —                    | —                  | 120 mA <sup>1,2</sup> |
| +15 VDC ( $\pm 5\%$ )  | 20 mA <sup>1</sup>  | 20 mA <sup>1</sup>   | 30 mA <sup>1</sup> | 20 mA                 |
| -15 VDC ( $\pm 5\%$ )  | -7 mA               | -7 mA                | —                  | —                     |
| +24 VDC ( $\pm 5\%$ )  | 2 mA                | —                    | —                  | —                     |
| <sup>1</sup> All eight channels loaded<br><sup>2</sup> The maximum current available on the +12 V supply of the VXI-SC-1150 submodule is 62 mA per SCMP. Additional current used is subtracted from the +12 V current available to other SCMPs on the VXI-SC-1150 submodule. |                     |                      |                    |                       |

## Physical

Dimensions .....7.239 by 5.664 cm  
(2.85 by 2.23 in.)

### I/O Connector

I/O signals .....24 (2 by 12) pin header  
connector

### Power and communication

connector .....28 (2 by 14) pin header  
connector

## Environment

Operating temperature .....0° C to 50° C

Storage temperature .....-55° C to 125° C

Relative humidity .....5% to 90% noncondensing

## Voltage Excitation

These specifications are for the 1 V, 2 V, 5 V, and 10 V SCMPs.

## Stability

Recommended warm-up time ..... 10 min.

## Excitation

|   | SCMP-1V                                     | SCMP-2V             | SCMP-5V            | SCMP-10V           |
|---|---|---------------------|--------------------|--------------------|
| Channels  | One voltage source, connected to 8 channels |                     |                    |                    |
| Level   | 1 V   | 2 V                 | 5 V                | 10 V               |
| Accuracy  | ±0.025%                                     | ±0.025%             | ±0.025%            | ±0.025%            |
| Current Drive (total)   | 84 mA                                       | 151 mA <sup>1</sup> | 88 mA <sup>1</sup> | 61 mA <sup>1</sup> |
| Drift   | ±2 ppm/°C                                   | ±2 ppm/°C           | ±2 ppm/°C          | ±2 ppm/°C          |
| Max. Current Limit (total)  | 84-145 mA                                   | 170-210 mA          | 417-505 mA         | 290-350 mA         |
| Over-voltage Protection   | ±40 V                                       | ±40 V               | ±40 V              | ±40 V              |
| <sup>1</sup> Exceeding this current drive (up to the maximum current limit) is allowed, but will reduce power available to other pods on the VXI-SC-1150. |   |                     |                    |                    |

## Bridge Specifications

Bridge type..... Half or full, with sockets for quarter-bridge completion

Bridge completion ..... two 10 kΩ resistors, 0.02% ratio tolerance, ±2 ppm/°C tracking TCR

## Power Requirement

|  | SCMP-1V            | SCMP-2V             | SCMP-5V             | SCMP-10V           |
|--|--------------------|---------------------|---------------------|--------------------|
| + 5 VDC ( $\pm 5\%$ )  | 89 mA <sup>1</sup> | 156 mA <sup>1</sup> | 156 mA <sup>2</sup> | 5 mA               |
| + 12 VDC ( $\pm 5\%$ )   | —                  | —                   | —                   | 62 mA <sup>3</sup> |
| + 15 VDC ( $\pm 5\%$ )   | 11 mA              | 11 mA               | 11 mA               | 10 mA              |
| - 15 VDC ( $\pm 5\%$ )   | -8 mA              | -8 mA               | —                   | —                  |
| + 24 VDC ( $\pm 5\%$ )   | —                  | —                   | —                   | 1 mA               |
| <sup>1</sup> Current drive supplied from this power line<br>Power requirement = 5 mA + current drive (total)<br><sup>2</sup> Current drive supplied from this power line. Power requirement for current drive is approximately = 10 mA + [current drive (total) x 1.72] mA<br><sup>3</sup> Current drive supplied from this power line<br>Power requirement = 1 mA + current drive (total) |                    |                     |                     |                    |

## Physical

Dimensions .....7.239 by 5.664 cm  
( 2.85 by 2.23 in.)

### I/O connector

I/O signals .....24 (2 by 12) pin header connector

### Power and communication

connector .....28 (2 by 14) pin header connector

## Environment

Operating temperature .....0° C to 50° C

Storage temperature .....-55° C to 125° C

Relative humidity .....5% to 90% noncondensing

# Customer Communication

---

Appendix

**B**

For your convenience, this appendix contains forms to help you gather the information necessary to help us solve your technical problems and a form you can use to comment on the product documentation. When you contact us, we need the information on the Technical Support Form and the configuration form, if your manual contains one, about your system configuration to answer your questions as quickly as possible.

National Instruments has technical assistance through electronic, fax, and telephone systems to quickly provide the information you need. Our electronic services include a bulletin board service, an FTP site, a Fax-on-Demand system, and e-mail support. If you have a hardware or software problem, first try the electronic support systems. If the information available on these systems does not answer your questions, we offer fax and telephone support through our technical support centers, which are staffed by applications engineers.

## Electronic Services



### Bulletin Board Support

National Instruments has BBS and FTP sites dedicated for 24-hour support with a collection of files and documents to answer most common customer questions. From these sites, you can also download the latest instrument drivers, updates, and example programs. For recorded instructions on how to use the bulletin board and FTP services and for BBS automated information, call (512) 795-6990. You can access these services at:

United States: (512) 794-5422

Up to 14,400 baud, 8 data bits, 1 stop bit, no parity

United Kingdom: 01635 551422

Up to 9,600 baud, 8 data bits, 1 stop bit, no parity

France: 01 48 65 15 59

Up to 9,600 baud, 8 data bits, 1 stop bit, no parity



### FTP Support

To access our FTP site, log on to our Internet host, `ftp.natinst.com`, as `anonymous` and use your Internet address, such as `joesmith@anywhere.com`, as your password. The support files and documents are located in the `/support` directories.



## Fax-On-Demand Support

Fax-on-Demand is a 24-hour information retrieval system containing a library of documents on a wide range of technical information. You can access Fax-on-Demand from a touch-tone telephone at (512) 418-1111.



## E-Mail Support (currently U.S. only)

You can submit technical support questions to the applications engineering team through e-mail at the Internet address listed below. Remember to include your name, address, and phone number so we can contact you with solutions and suggestions.

[support@natinst.com](mailto:support@natinst.com)

## Telephone and Fax Support

National Instruments has branch offices all over the world. Use the list below to find the technical support number for your country. If there is no National Instruments office in your country, contact the source from which you purchased your software to obtain support.

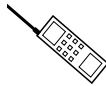

### Telephone



### Fax

|                  |                 |                  |
|------------------|-----------------|------------------|
| Australia        | 03 9879 5166    | 03 9879 6277     |
| Austria          | 0662 45 79 90 0 | 0662 45 79 90 19 |
| Belgium          | 02 757 00 20    | 02 757 03 11     |
| Canada (Ontario) | 905 785 0085    | 905 785 0086     |
| Canada (Quebec)  | 514 694 8521    | 514 694 4399     |
| Denmark          | 45 76 26 00     | 45 76 26 02      |
| Finland          | 09 527 2321     | 09 502 2930      |
| France           | 01 48 14 24 24  | 01 48 14 24 14   |
| Germany          | 089 741 31 30   | 089 714 60 35    |
| Hong Kong        | 2645 3186       | 2686 8505        |
| Israel           | 03 5734815      | 03 5734816       |
| Italy            | 02 413091       | 02 41309215      |
| Japan            | 03 5472 2970    | 03 5472 2977     |
| Korea            | 02 596 7456     | 02 596 7455      |
| Mexico           | 5 520 2635      | 5 520 3282       |
| Netherlands      | 0348 433466     | 0348 430673      |
| Norway           | 32 84 84 00     | 32 84 86 00      |
| Singapore        | 2265886         | 2265887          |
| Spain            | 91 640 0085     | 91 640 0533      |
| Sweden           | 08 730 49 70    | 08 730 43 70     |
| Switzerland      | 056 200 51 51   | 056 200 51 55    |
| Taiwan           | 02 377 1200     | 02 737 4644      |
| U.K.             | 01635 523545    | 01635 523154     |

# Technical Support Form

Photocopy this form and update it each time you make changes to your software or hardware, and use the completed copy of this form as a reference for your current configuration. Completing this form accurately before contacting National Instruments for technical support helps our applications engineers answer your questions more efficiently.

If you are using any National Instruments hardware or software products related to this problem, include the configuration forms from their user manuals. Include additional pages if necessary.

Name \_\_\_\_\_

Company \_\_\_\_\_

Address \_\_\_\_\_

\_\_\_\_\_

Fax (\_\_\_\_) \_\_\_\_\_ Phone (\_\_\_\_) \_\_\_\_\_

Computer brand \_\_\_\_\_ Model \_\_\_\_\_ Processor \_\_\_\_\_

Operating system (include version number) \_\_\_\_\_

Clock speed \_\_\_\_\_ MHz RAM \_\_\_\_\_ MB \_\_\_\_\_ Display adapter \_\_\_\_\_

Mouse \_\_\_yes \_\_\_no Other adapters installed \_\_\_\_\_

Hard disk capacity \_\_\_\_\_ MB \_\_\_\_\_ Brand \_\_\_\_\_

Instruments used \_\_\_\_\_

\_\_\_\_\_

National Instruments hardware product model \_\_\_\_\_ Revision \_\_\_\_\_

Configuration \_\_\_\_\_

National Instruments software product \_\_\_\_\_ Version \_\_\_\_\_

Configuration \_\_\_\_\_

The problem is: \_\_\_\_\_

\_\_\_\_\_

\_\_\_\_\_

\_\_\_\_\_

\_\_\_\_\_

List any error messages: \_\_\_\_\_

\_\_\_\_\_

\_\_\_\_\_

The following steps reproduce the problem: \_\_\_\_\_

\_\_\_\_\_

\_\_\_\_\_

\_\_\_\_\_

\_\_\_\_\_

\_\_\_\_\_

# VXI-SC-1150 and SCMP Hardware and Software Configuration Form

Record the settings and revisions of your hardware and software on the line to the right of each item. Complete a new copy of this form each time you revise your software or hardware configuration, and use this form as a reference for your current configuration. Completing this form accurately before contacting National Instruments for technical support helps our applications engineers answer your questions more efficiently.

## National Instruments Products

DAQ hardware \_\_\_\_\_

Signal conditioning \_\_\_\_\_

Programming choice \_\_\_\_\_

ComponentWorks, NI-DAQ, LabVIEW, LabWindows/CVI, or VirtualBench version \_\_\_\_\_

Other boards in system \_\_\_\_\_

Installed quarter-bridge completion resistor values or 0  $\Omega$  resistor

| Resistor | Resistor Value |          |          |          |
|----------|----------------|----------|----------|----------|
|          | Socket 0       | Socket 1 | Socket 2 | Socket 3 |
| R12      |                |          |          |          |
| R14      |                |          |          |          |
| R23      |                |          |          |          |
| R25      |                |          |          |          |
| R13      |                |          |          |          |
| R15      |                |          |          |          |
| R24      |                |          |          |          |
| R26      |                |          |          |          |

## Other Products

Computer make and model \_\_\_\_\_

Microprocessor \_\_\_\_\_

Clock frequency or speed \_\_\_\_\_

Type of video board installed \_\_\_\_\_

Operating system version \_\_\_\_\_

Operating system mode \_\_\_\_\_

Programming language \_\_\_\_\_

Programming language version \_\_\_\_\_

Other boards in system \_\_\_\_\_

Base I/O address of other boards \_\_\_\_\_

DMA channels of other boards \_\_\_\_\_

Interrupt level of other boards \_\_\_\_\_



# Documentation Comment Form

National Instruments encourages you to comment on the documentation supplied with our products. This information helps us provide quality products to meet your needs.

**Title:** *SCMP and Carrier System User Manual*

**Edition Date:** February 1997

**Part Number:** 321453A-01

Please comment on the completeness, clarity, and organization of the manual.

---

---

---

---

---

---

---

---

If you find errors in the manual, please record the page numbers and describe the errors.

---

---

---

---

---

---

---

---

Thank you for your help.

Name \_\_\_\_\_

Title \_\_\_\_\_

Company \_\_\_\_\_

Address \_\_\_\_\_

---

Phone (\_\_\_\_) \_\_\_\_\_ Fax (\_\_\_\_) \_\_\_\_\_

**Mail to:** Technical Publications  
National Instruments Corporation  
6504 Bridge Point Parkway  
Austin, TX 78730-5039

**Fax to:** Technical Publications  
National Instruments Corporation  
(512) 794-5678

| <b>Prefix</b> | <b>Meaning</b> | <b>Value</b> |
|---------------|----------------|--------------|
| p-            | pico-          | $10^{-12}$   |
| n-            | nano-          | $10^{-9}$    |
| $\mu$ -       | micro-         | $10^{-6}$    |
| m-            | milli-         | $10^{-3}$    |
| k-            | kilo-          | $10^3$       |
| M-            | mega-          | $10^6$       |
| G-            | giga-          | $10^{12}$    |

## **Numbers/Symbols**

|          |                |
|----------|----------------|
| +5 V     | +5 volt signal |
| °        | degrees        |
| $\Omega$ | ohms           |
| %        | percent        |
| ±        | plus or minus  |

## **A**

|     |                     |
|-----|---------------------|
| AC  | alternating current |
| A/D | analog-to-digital   |

**ADC** analog-to-digital converter—an electronic device, often an integrated circuit, that converts an analog voltage to a digital number

**amplification** a type of signal conditioning that improves accuracy in the resulting digitized signal and reduces noise

## **B**

**bus** the group of conductors that interconnect individual circuitry in a computer. Typically, a bus is the expansion vehicle to which I/O or other devices are connected. Examples of PC buses are the AT bus, NuBus, Micro Channel, and EISA bus.

## **C**

**C** Celsius

**channel** pin or wire lead to which you apply or from which you read the analog or digital signal. Analog signals can be single-ended or differential. For digital signals, you group channels to form ports. Ports usually consist of either four or eight digital channels.

**CH<0..31> -** negative input channels 0 through 31

**CH<0..31>+** positive input channels 0 through 31

**cold-junction compensation** a method of compensating for inaccuracies in thermocouple circuits

## **D**

**D/A** digital-to-analog

**DAQ** data acquisition—(1) collecting and measuring electrical signals from sensors, transducers, and test probes or fixtures and inputting them to a computer for processing; (2) collecting and measuring the same kinds of electrical signals with A/D and/or DIO boards plugged into a computer, and possibly generating control signals with D/A and/or DIO boards in the same computer

|                         |   |
|-------------------------|---|
| DC                      | direct current  |
| default setting         | a default parameter value recorded in the driver. In many cases, the default input of a control is a certain value (often 0) that means <i>use the current default setting</i> . For example, the default input for a parameter may be <i>do not change current setting</i> , and the default setting may be <i>no AMUX-64T boards</i> . If you do change the value of such a parameter, the new value becomes the new setting. You can set default settings for some parameters in the configuration utility or manually using switches located on the device. |
| DIFF                    | differential configuration  |
| differential input      | an analog input consisting of two terminals, both of which are isolated from computer ground, whose difference is measured  |
| DMA                     | direct memory access—a method by which data can be transferred to/from computer memory from/to a device or memory on the bus while the processor does something else. DMA is the fastest method of transferring data to/from computer memory.   |
| DNL                     | differential nonlinearity—a measure in LSB of the worst-case deviation of code widths from their ideal value of 1 LSB   |
| drivers/driver software | software that controls a specific hardware device such as a DAQ board   |

## F

|      |   |
|------|---|
| FIFO | first-in first-out memory buffer—the first data stored is the first data sent to the acceptor. FIFOs are often used on DAQ devices to temporarily store incoming or outgoing data until that data can be retrieved or output. For example, an analog input FIFO stores the results of A/D conversions until the data can be retrieved into system memory, a process that requires the servicing of interrupts and often the programming of the DMA controller. This process can take several milliseconds in some cases. During this time, data accumulates in the FIFO for future retrieval. With a larger FIFO, longer latencies can be tolerated. In the case of analog output, a FIFO permits faster update rates, because the waveform data can be stored on the FIFO ahead of time. This again reduces the effect of latencies associated with getting the data from system memory to the DAQ device. |
|------|---|

filtering                      a type of signal conditioning that allows you to filter unwanted signals from the signal you are trying to measure

## **G**

G                                  gain—the factor by which a signal is amplified, sometimes expressed in decibels

## **H**

hex                              hexadecimal

Hz                                hertz—the number of scans read or updates written per second

## **I**

in.                                inches

input impedance              the measured resistance and capacitance between the input terminals of a circuit

I/O                                input/output—the transfer of data to/from a computer system involving communications channels, operator interface devices, and/or data acquisition and control interfaces

ISA                                Industry Standard Architecture

## **L**

LED                                light-emitting diode

logical address                An 8-bit number that uniquely identifies each VXIbus device in a system. It defines the A16 register addresses of a device, and indicates Commander and Servant relationships.

LSB                                least significant bit

**M**

|           |   |
|-----------|---|
| mainframe | The chassis of a VXIbus system that mechanically contains VXI modules inserted into the backplane, ensuring that connectors fit properly and that adjacent modules do not contact each other. It also provides cooling airflow, and ensures that modules do not disengage from the backplane due to vibration or shock. |
| MB        | megabytes of memory   |
| MIO       | multifunction I/O   |
| MSB       | most significant bit  |
| mux       | multiplexer—a switching device with multiple inputs that sequentially connects each of its inputs to its output, typically at high speeds, in order to measure several signals with a single analog input channel   |

**N**

|       |   |
|-------|---|
| NC    | not connected (signal)  |
| noise | an undesirable electrical signal—Noise comes from external sources such as the AC power line, motors, generators, transformers, fluorescent lights, soldering irons, CRT displays, computers, electrical storms, welders, radio transmitters, and internal sources such as semiconductors, resistors, and capacitors. Noise corrupts signals you are trying to send or receive. |
| NRSE  | nonreferenced single-ended mode—all measurements are made with respect to a common (NRSE) measurement system reference, but the voltage at this reference can vary with respect to the measurement system ground  |

**R**

|                   |   |
|-------------------|---|
| RAM               | random-access memory  |
| relative accuracy | a measure in LSB of the accuracy of an ADC. It includes all non-linearity and quantization errors. It does not include offset and gain errors of the circuitry feeding the ADC. |

RMA Return Material Authorization

rms root mean square

## S

S samples

s seconds

signal conditioning the manipulation of signals to prepare them for digitizing

slot A position where a module can be inserted into a VXIbus backplane. Each slot provides the 96-pin J connectors to interface with the board P connectors. A slot can have one, two, or three connectors.

socket A position where an SCMP can be inserted onto a VXI-SC-1150 submodule. Each socket provides a 28-pin power and communication connector and a 24-pin signal connector to interface with the SCMP connectors.

## T

TCR temperature coefficient of resistance. A measure of the variation of resistance with temperature

thermocouple a temperature sensor created by joining two dissimilar metals. The junction produces a small voltage as a function of the temperature.

transducer excitation a type of signal conditioning that uses external voltages and currents to excite the circuitry of a signal conditioning system into measuring physical phenomena

## V

V volts

VDC volts, direct current

VISA a new driver software architecture developed by National Instruments to unify instrumentation software GPIB, DAQ, and VXI. It has been accepted as a standard for VXI by the *VXIplug&play* Systems Alliance.

VXIbus

VMEbus eXtensions for Instrumentation

VXI*plug&play*  
Systems Alliance

A group of VXI developers dedicated to making VXI devices as easy to use as possible, primarily by simplifying software development

## **W**

waveform

multiple voltage readings taken at a specific sampling rate



## **B**

bridge specifications, voltage excitation, A-4  
bulletin board support, B-1

## **C**

ComponentWorks software, 1-4  
current excitation, 3-1 to 3-3

- current excitation products (table), 3-1
- pin assignments, 4-1 to 4-3
  - SCMP socket 0 (figure), 4-1
  - SCMP socket 1 (figure), 4-2
  - SCMP socket 2 (figure), 4-2
  - SCMP socket 3 (figure), 4-2
- power sharing, 3-2
- specifications, A-2 to A-3
  - bridge specifications, A-4
  - environment, A-3
  - excitation (table), A-2
  - physical, A-3
  - power requirement (table), A-3
  - stability, A-2
- transducer connection and wiring, 3-2 to 3-3
  - four-wire configuration (figure), 3-3
  - full-bridge configuration (figure), 3-3
  - three-wire configuration (figure), 3-3
  - two-wire configuration (figure), 3-3

customer communication, *ix*, B-1 to B-2

## **D**

documentation

- conventions used in manual, *viii*

National Instruments documentation, *viii-ix*  
organization of manual, *vii*  
related documentation, *ix*

## **E**

electronic support services, B-1 to B-2  
e-mail support, B-2  
environment specifications

- current excitation, A-3
- voltage excitation, A-4

equipment, optional, 1-6

## **F**

fax and telephone support, B-2  
Fax-On-Demand support, B-2  
FTP support, B-1

## **H**

hardware overview of SCMPs

- current excitation, 3-1 to 3-3
  - current excitation products (table), 3-1
  - power sharing, 3-2
  - transducer connection and wiring, 3-2 to 3-3
- voltage excitation, 3-4 to 3-9
  - power sharing, 3-6 to 3-7
  - quarter-bridge completion resistors (figure), 3-5
    - and corresponding channels (table), 3-5

- transducer connection and wiring,
  - 3-7 to 3-9
- voltage excitation products  
(table), 3-4

## I

- installation
  - installing SCMPs into SCMP sockets,
    - 2-1 to 2-2
  - (figure), 2-2
  - unpacking the VXI-SC-1105  
submodule, 1-6

## L

- LabVIEW application software, 1-4
- LabWindows/CVI application software, 1-4

## M

- manual. *See* documentation.

## N

- National Instruments application software, 1-4
- NI-DAQ driver software, 1-4 to 1-5

## P

- physical specifications
  - current excitation, A-3
  - voltage excitation, A-4
  - VXI-SC-1105 submodule, A-1
- pin assignments
  - current excitation SCMP, 4-1 to 4-3
    - SCMP socket 0 (figure), 4-1
    - SCMP socket 1 (figure), 4-2
    - SCMP socket 2 (figure), 4-2
    - SCMP socket 3 (figure), 4-2
  - voltage excitation SCMP, 4-3 to 4-5

- SCMP socket 0 (figure), 4-3
- SCMP socket 1 (figure), 4-4
- SCMP socket 2 (figure), 4-4
- SCMP socket 3 (figure), 4-4

### power sharing

- current excitation, 3-2
- voltage excitation, 3-6 to 3-7

### power specifications

- current excitation, A-3
- voltage excitation, A-5
- VXI-SC-1105 submodule, A-1

## R

- requirements for getting started, 1-3

## S

### SCMPs

- components of VXI signal conditioning  
system (figure), 1-2
- definition, 1-1
- installing into SCMP sockets, 2-1 to 2-2
- location of sockets (figure), 2-2

- signal conditioning minipods. *See* SCMPs.

### signal connections

- current excitation SCMP pin assignments,
  - 4-1 to 4-3
    - SCMP socket 0 (figure), 4-1
    - SCMP socket 1 (figure), 4-2
    - SCMP socket 2 (figure), 4-2
    - SCMP socket 3 (figure), 4-2

### voltage excitation SCMP pin assignments, 4-3 to 4-5

- SCMP socket 0 (figure), 4-3
- SCMP socket 1 (figure), 4-4
- SCMP socket 2 (figure), 4-4
- SCMP socket 3 (figure), 4-4

- software programming choices, 1-3 to 1-5

- National Instruments application software, 1-4
- NI-DAQ driver software, 1-4 to 1-5
- VXI*plug&play* instrument driver, 1-5

#### specifications

##### SCMP

- current excitation, A-2 to A-3
- voltage excitation, A-4 to A-5

- VXI-SC-1105 submodule, A-1

#### stability specifications

- current excitation, A-2
- voltage excitation, A-4

## T

- technical support, B-1 to B-2

- telephone and fax support, B-2

#### transducer connection and wiring

- current excitation, 3-2 to 3-3
  - four-wire configuration (figure), 3-3
  - full-bridge configuration (figure), 3-3
  - three-wire configuration (figure), 3-3
  - two-wire configuration (figure), 3-3

- voltage excitation, 3-7 to 3-9

- full-bridge configuration (figure), 3-9

- half-bridge configuration (figure), 3-9

- quarter-bridge configuration (figure), 3-9

## U

- unpacking the VXI-SC-1105 submodule, 1-6

## V

- VirtualBench software, 1-4

- voltage excitation, 3-4 to 3-9
  - power sharing, 3-6 to 3-7

- quarter-bridge completion resistors (figure), 3-5

- and corresponding channels (table), 3-5

- SCMP pin assignments, 4-3 to 4-5

- SCMP socket 0 (figure), 4-3

- SCMP socket 1 (figure), 4-4

- SCMP socket 2 (figure), 4-4

- SCMP socket 3 (figure), 4-4

- specifications, A-4 to A-5

- environment, A-5

- excitation (table), A-4

- physical, A-5

- power requirement (table), A-5

- stability, A-4

- transducer connection and wiring, 3-7 to 3-9

- full-bridge configuration (table), 3-9

- half-bridge configuration (figure), 3-9

- quarter-bridge configuration (figure), 3-9

- voltage excitation products (table), 3-4

- VXI*plug&play* instrument driver, 1-5

- VXI-SC-1105 submodule

- components, 1-1 to 1-2

- optional equipment, 1-6

- overview, 1-1 to 1-3

- requirements for getting started, 1-3

- software programming choices, 1-3 to 1-5

- National Instruments application software, 1-4

- NI-DAQ driver software, 1-4 to 1-5

- VXI*plug&play* instrument driver, 1-5

- specifications, A-1

- unpacking, 1-6